

GV-NET / IO Card (125V)

The GV-NET/IO Card is a RS-485 / RS-232 interface converter with 4 points inputs and 4 points relay outputs.

Installation

Insert the GV-NET/IO card to an empty card slot. Connect the 20P ribbon cable to the video capture card as shown below. Connect one of the PC power supply's 4 pins-mini cable to the GV-NET/IO card's power input connector.

Packing List

- ❶ GV-NET I/O Card x1
- ❷ 20P Ribbon Cable x1
- ❸ RJ-11 to DB9 Cable x1
- ❹ 4pins to 4pins Mini Power Cable x 1

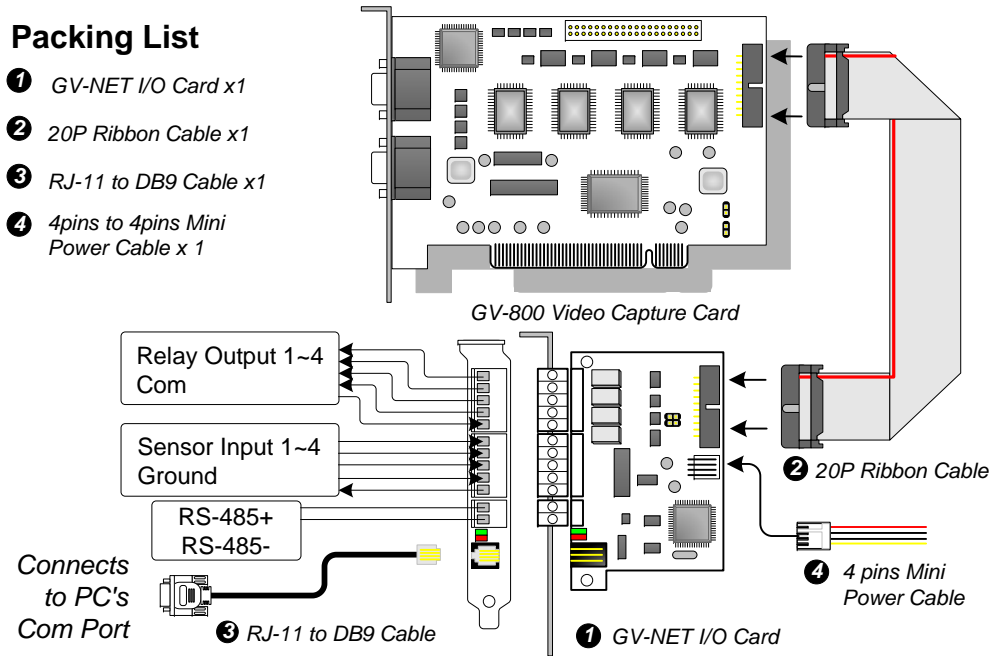

Specification

Input	Input	4
	Input Signal	5V DC (floating) / TTL
	High State	5V
	Low State	0V
Output	Relay Output	4
	Relay Status	Normal Open
	Relay Capacitance	1A / 30V DC; 0.3A / 125V AC
	Relay On/ Off Time	4ms / 4ms
Communication	RS-485 1,200~19,200bps	
DC IN	DC 5V, 1A	
Environmental Condition	0 to 50 degree C , 5%~95% (non-condensing)	
Models Supported	GV-600 V3, GV-650 V3, GV-800 V3, GV-900 V1.11, GV-1000 V1.21, GV-1120, GV-1240 and GV-1480	

Connecting Output Devices

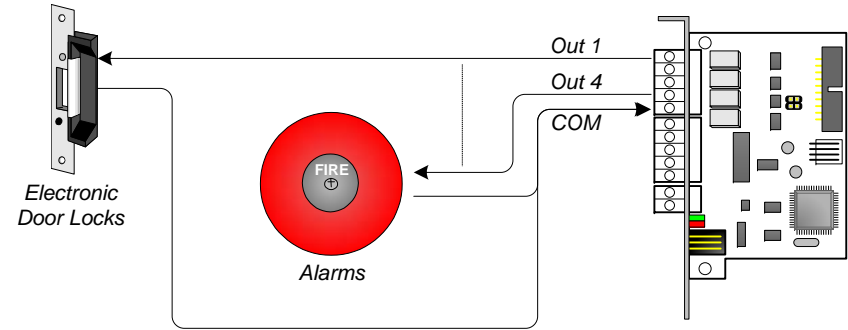

Connecting Input Devices

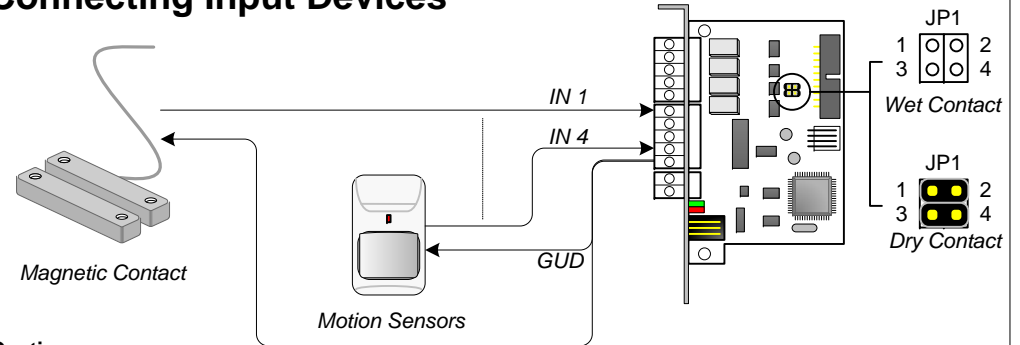

Caution:

1. Use JP1 to switch between dry contact and 5~12V wet contact.
2. GV-NET/IO card accepts either all dry contact or all wet contact devices. Don't mix two different contact devices to the same card.
3. Make sure that jumpers are in the correct direction. If the jumper is at the position of 1st and 3rd pin, or 2nd and 4th pin, it will create the short circuit of PC or burn the ribbon cable.

Connecting RS-485 Devices (PTZ Dome / GV-IO)

